

Adjustable Base

ERJXS0205M7W Wireless



Owner's Manual

INNOVA[™]

SLEEP SYSTEMS

CONTENTS

Advisory

Setup and Installation

Wireless Hand Control

1-3-20 year Warranty

ADVISORY

Attention: Read the following information before using this product . Failure to use a surge protection device could compromise safety or cause product malfunction could void the electrical portion of your warranty.

– Electrical surges are by far the biggest cause of problems with electrical circuits.

In order to help protect your investment in case of a power surge or outage, use an electrical surge protection device (not included).

WARRANTY WARNING!

Do not open or tamper with the transformer, control box, motors, or remote control (with the exception of battery compartments). The product warranty will be void if these components are tampered with.

SMALL CHILDREN AND PETS:

Immediately dispose of all packing materials as it can smother small children and pets. Do not allow any person or pets under the bed. Children, convalescents and disabled person should not operate the bed without adult supervision.

HOSPITAL OR CONVALESCENT USE DISCLAIMER:

Adjustable beds are designed and engineered for a life style of in-home comfort and are not intended for hospital use or for a bed-ridden patient on an extended recovery. Adjustable beds are not equipped with bars to help patients get safely in and out of bed and are not intended to be used around tent type oxygen therapy or explosive gases.

PACEMAKER WARNING:

The massagers in this bed produce mechanical vibrations that may

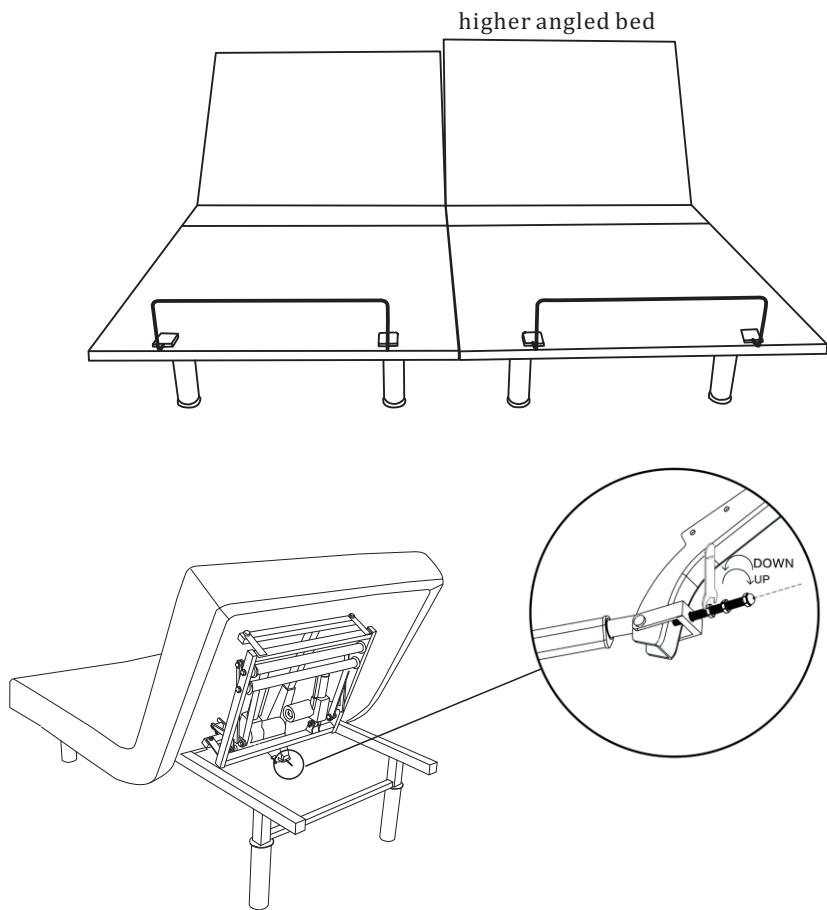

WHEN TWO BEDS DO NOT ALIGN:
 on the higher angled bed of the two, use a 19mm wrench to turn the nuts on the new “LEVEL RIGHT” counterclockwise to adjust the angle until the higher angle bed match the level of the lower angle bed and lock the nut with the reinforce nuts.

The two beds are now aligned.

activate a special sensor in your pacemaker that detects motion. This can fool the pacemaker into “thinking” you are engaged in some sort of physical activity and require a faster heart rate and you may experience a sensation similar to when you are exercising. Consult your physician for further information.

PRODUCT RATINGS:

The product’s lift motors are not designed for continuous use of more than 2 minutes in an 18 minute period, or approximately 10% duty cycle. For every 30 minutes the massage motor is used, the massage motor needs 30 minutes of rest. The massage function should be used for a maximum of 2 hours in a 12 hour period. Any attempt to circumvent or exceed this rating will shorten the life expectancy of the product and may void the warranty.

WEIGHT UNITS:

The limitation for this adjustable bed is 850 lbs. The bed will structurally support these weights, provided it is evenly distributed across the head and foot sections. This product is not designed to support or lift this amount in the head or foot section alone. Exceeding this weight restriction could damage the bed and/or cause injury and void the warranty. Enter or exit the bed in a flat position and do not sit on the head or foot sections while in the raised position.

LIFTING AND LOWERING MECHANISMS AND MASSAGE UNITS:

It is normal for the raising and lowering feature on this bed will emit a minimal humming sound during operation. The massage feature creates a vibrating hum during operation and the resonance will increase accordingly with a higher intensity motor setting.

LOCATION ENVIRONMENT:

The level of sound experienced in a room is directly related to the environment within that location. In a room with hardwood floors and the massagers turned on, a vibrating noise can be noticeable. To reduce the resonance, place a piece of carpet or rubber casters cups under the legs. The rubber caster cups also prevent the bed sliding when located on smooth or hard surface flooring.

TO REDUCE THE RISK OF SHOCK, BURNS, FIRE OR INJURY:

Make sure the base is in a flat position, the vibrating motors are off before unplug from power source. Always unplug the base from the electrical outlet before cleaning or servicing the base. If the cord or plug is damaged, discontinue use of the bed base and contact qualified service personnel for examination and repair.

FCC COMPLIANCE:

This device complies with part 15 of the FCC Rules for residential use. Operation is subject to the following two conditions: (1) This device may not cause harmful interference, and (2) this device must accept any interference received, including interference that may cause undesired operation.

Radio Frequency: 2.4 GHz

EMERGENCY BATTERY BACKUP:

In the event that the base is stuck in an articulated position during a power outage-the battery backup in the transformer will return the base to flat position. Batteries are not to be used for normal operation of the base. Install two 9 volt alkaline batteries into the battery backing transformer. Use the reset button on the control box or the extension cord from the control box to the transformer to return the base to a flat position.

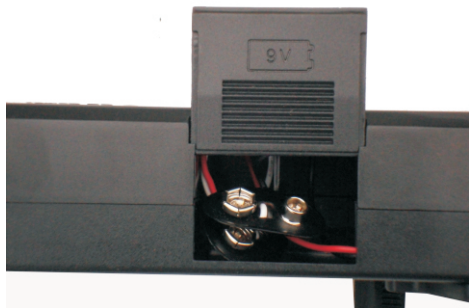

receive all service and transportation cost for verification . In years 4-5 years , purchaser shall pay all service and transportation costs related to the replacement of the defective part and required to pay 1/10 of the current replacement cost of the parts times the number of years used. In years 6-20 years, purchaser shall pay all service and transportation costs related to the replacement of the defective part and required to pay 60% of the replacement parts cost and pay 2% of the current replacement cost of the parts times the number of years used.

ADDITIONAL TERMS AND CONDITIONS

This warranty does not apply: (a) to any damage caused by the purchaser; (b) if there has been any repair or replacement of adjustable bed parts by an unauthorized person; (c) if the adjustable bed has been mishandled (whether in transit or by other means), viz, subjected to physical or electrical abuse or misuse, or otherwise operated in any manner inconsistent with the operation and maintenance procedures outlined in the Owner's Manual and this warranty; (d) to damage to mattresses, fabric, cables, electrical cords or items supplied by dealers. (Contact the dealers for warranty information on those items;) (e) if there has been any modification of the adjustable bed without prior written consent by INNOVA; (f) to costs for unnecessary service calls, including costs for in-home service calls solely for the purpose of education the consumer about the adjustable bed or finding an unsatisfactory power connection; (g) if the recommended weight restriction is not followed (refer to the advisory section of this manual), the warranty will be void; (h) to the use of the adjustable bed base in whatsoever and howsoever manner other than the personal in home use exclusively by the purchaser. Repairs to or replacement of an adjustable bed base or its components under the terms of this limited warranty will apply to the original warranty period and will not serve to extend such period. The decision to repair or to replace defective parts under this warranty shall be made, or cause to be made, by INNOVA at its option and in its sole discretion. Repair or replacement shall be the sole remedy available to the purchaser. There shall be no liability on the part of INNOVA for any special, indirect, incidental, or consequential damages or to any other damage, claim, or loss not expressly covered by the terms of this warranty. This limited warranty does not include reimbursement for inconvenience, removal, installation, setup time, loss of use, shipping, or any other costs of expenses, INNOVA /or its service technicians shall not be responsible for moving furniture or any other items not originally attached to the adjustable bed in order to perform service on the adjustable bed. It is the sole responsibility of the purchaser to provide adequate space and accessibility to the adjustable bed. In the event that the technician is unable to perform service due to lack of accessibility, the service call will be billed to the purchaser and the service will have to be rescheduled. INNOVA makes no other warranty whether expressed or implied, and all implied warranties of merchantability and fitness for a particular purpose are disclaimed by INNOVA and excluded from this warranty. Some states do not allow the exclusion or limitation of incidental or consequential damages, so the above limitation or exclusion may not apply to every purchaser. This warranty gives the purchaser specific legal rights, and the purchaser may also have other rights, which may vary from state to state. This warranty is valid in all 50 states, Puerto Rico, and Canada.

INNOVA SLEEP PRODUCT

1, 3 & 20 YEAR LIMITED WARRANTY

Innova Sleep Products, Inc. (“Innova”) warrants this adjustable bed to the consumer who is the original purchaser of a new product which was not sold “as is” (the “purchaser”), subject to the terms and conditions set forth herein. This warranty begins on the “warranty commencement date” which is the date of purchase for new unused beds base. But not more then 3 years from the date of manufacture.

Part Name	Parts warranty period	Labor warranty period
Motor(s)	3 years	first year
Transformer(s)	3 years	first year
Control box(es)	3 years	first year
Remote control	1 year	
USB	1 year	
under bed light	1 year	

During the Parts warranty period, there will be no charge for parts. During the Labor warranty period, there will be no charge for labor. If repair is needed during the warranty period, the purchaser will be required to produce a sales receipt/proof of purchase evidencing the date of purchase, the amount paid and the place of purchase. If no such sales receipt/proof of purchase is produced, full amount of charges for labor and the parts shall be paid before any services could be rendered.

FULL first YEAR WARRANTY

This adjustable bed is warranted against defects in the workmanship or materials for a period of first year from the warranty commencement date. Upon notice during the first year after the warranty commencement date, INNOVA will repair or replace (at no cost to the purchaser) any defective adjustable bed base part with new or refurbished parts, and INNOVA will pay all authorized labor and transportation costs associated with the repair or replacement of any parts found to be defective. When the adjustable bed at hand is found to be DAMAGE, not DEFECT, all costs incurred to inspect and/or correct the requested issue will be the financial responsibility of the requesting party.

3 YEAR LIMITED WARRANTY

During the second year from the warranty commencement date, upon receipt of notice, INNOVA will replace any adjustable bed base part found to be defective with new or refurbished parts. Purchaser shall pay all service and transportation costs related to the replacement of the defective part. This limited three (3) year warranty shall not apply unless the defective part is returned to INNOVA and INNOVA receive all service and transportation cost for verification.

20 YEAR LIMITED WARRANTY

Upon written notice during the third year through the 20th year from the warranty commencement date, INNOVA will replace, upon terms and conditions set forth in this paragraph, any mechanical bed base parts found to be defective. Electronics, electrical components, drive motors and massage motors are also excluded. This limited lifetime warranty shall not apply unless the defective part is returned to INNOVA and INNOVA

SETUP and INSTALLATION

Important: We strongly recommend Two able-bodied adults setup and assemble this product.

Step 1:

Check and verify all parts are included before discarding any packing materials.

All electronics and components that need to be installed are located in boxes under the base or attached to the frame.

- A) Wireless Remote Control (1)
- B) Mattress Retainer Bar (1)
- C) Legs 3" +6" (4)
- D) Power Cord (1)
- E) Transformer with emergency battery backup (1)
- F) Control Box (1)

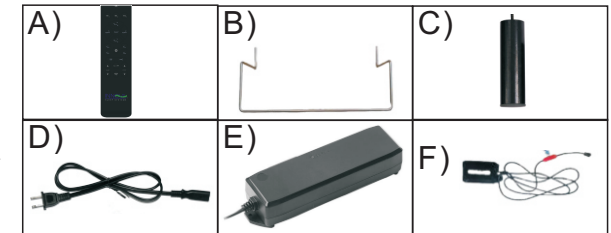

Step 2:

With the help of your able-bodied assistant, place carton on floor with arrows point downwards.

Step 3:

Connect the Transformer “E” to Control Box “F” : The Control Box is the Black Box attached to the bottom of the bed . Extend the Power Cord from the Control Box “F” and attach to the short electrical output cord on Transformer “E” . Extend the Power Cord “D” and plug it into the Transformer “E” . (See Figure 1)

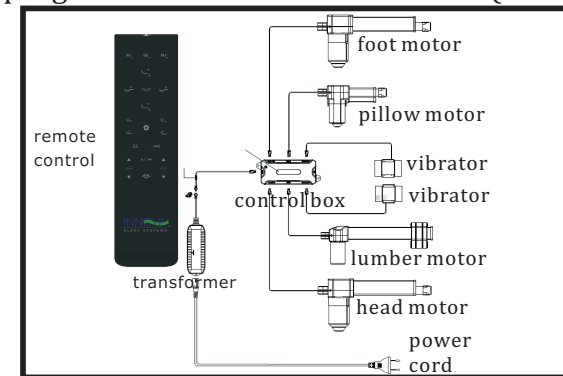

Figure 1

Step 4:
Insert 3 AAA batteries into the Wireless Remote.

Step 5:
Plug the Power Cord into a grounded electrical outlet. A surge protector is recommended.

Using the Wireless Remote Control, push the HEAD UP button and then push the HEAD DOWN button to test the bed. If the motors are working, skip to step 7.

NOTE: The actuator is a gravity down motor, which needs weight to be lowered.

Step 6:
Synchronize the Wireless Remote with the Control Box:
After plugging in the base to a grounded outlet, the base will return to flat position and you will hear a beep. At this time, it enters the pairing state for ten seconds. (If you have not completed pairing within ten seconds, press the orange SYNC button for 2-3 seconds.)
Press HEAD UP and HEAD DOWN buttons simultaneously for 3-5 seconds. (See Figure 2) You will hear a beep when syncing is successful. The adjustable bed should work after syncing the Wireless Remote with the Control Box. Press the HEAD UP button and then FOOT UP buttons to test. The pairing is complete. If you need to pair again, press the SYNC button on the power cord for 2-3 seconds until you hear a beep.

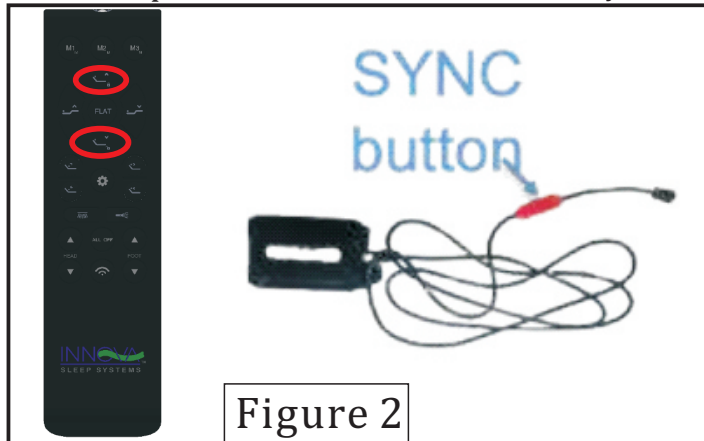

WE STRONGLY RECOMMEND:

In order to help protect your investment in case of a power surge or outage, use an electrical surge protection device with a battery backup system (not included) and plug it in to a grounded outlet.

How to Set and Remove Child Safety Locks:

The Child Safety Locks prevent the head and foot of the bed from moving from current settings until they are turned off. When the Child Safety Locks are engaged, the Remote will not sync to the Control Box.

To turn on Child Safety Locks:
Press the SET and HEAD UP buttons simultaneously for 5-8 seconds (Figure 6). The quick beeping sound will confirm the locks have been activated.



Figure 6

To turn off Child Safety Locks:
Press the SET and HEAD DOWN buttons simultaneously for around 5-8 seconds (Figure 7). The quick beeping sound will confirm the locks have been deactivated.

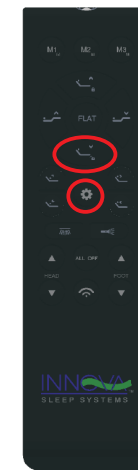
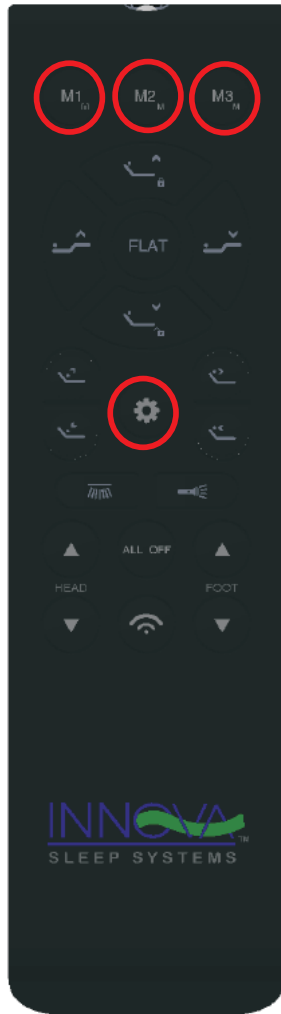

Figure 7

How to Program Memory Position Buttons:

The remote has 3 memory buttons: "M1", "M2", and "M3". These positions have been tested but have not been preprogrammed, as each user will have his/her own individual preferences.

1. In order to set each button, adjust the bed to the desired position.
2. Press and hold the memory button and the set button for 3 seconds simultaneously. A quick beeping sound will confirm that the setting has been successfully saved.
3. Each of the 3 position buttons (M1, M2 or M3) can be reset by repeating steps 1 and 2.



10-14

Step 7:

- Unplug the Power Cord.
- Install the four legs firmly into the base of the frame. The legs screw into the threaded holes in each corner of the adjustable base frame (See Figure 3). The legs are stackable. The combination give you a set of four 3", 6" or 9" legs. **The minimum height for this base is 0.8"**.
- Do not over tighten.

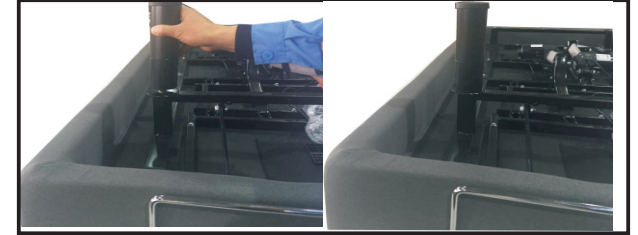

Figure 3

Step 8:

With the help of your able-bodied assistant, carefully lift the adjustable bed frame and set it in place upright on its legs. Excessive pressure may damage the legs. Remove all protective plastic covering. **Note: check and make sure that all power cords clear and do not interfere with any Adjustable Bed Mechanisms; Dispose of covering property to avoid injury.**

Step 9:

Note: The Mattress Retaining Bar is tied to the underside of the base for shipping. Install the Mattress Retaining Bar upright by carefully aligning and pushing the bar into place.

Insert the Mattress Retaining Bar into the holders at the foot of the bed. (Figure 4)

The Mattress Retaining Bar prevents the mattress from slipping off the base and should not be used as a handle of the base. Using as a handle will damage the retaining bar holders. Screws come out from the retainer bar holders will be considered as a damaged part and not a defective part and is not covered by the warranty.



See Figures 4

7-14

Wireless Remote Control Instructions

Memory Buttons

M1、M2、M3

Press once to adjust to preset memory positions.

Flat Button

Press to return to flat position.

Foot Down Button

Used to lower the foot of the bed base.

Set Button

Use to set memory positions.

Pillow Tilt Raise/Down Buttons

Use to raise or lower the Pillow tilt of the bed

Flash Light Button

Press and hold to turn the flash light on. Release the button to turn the flash light off.

Foot Massage Increase Button

Turn the foot massage on , Increase massage intensity for the foot.

Foot Massage Decrease Button

Once foot massage is turned on, press to decrease massage intensity. Once massage is at the lowest intensity, press again to turn massage off.

Massage Type Button

Push to switch between Pulse , Short Wave, Long Wave & Constant massage modes.

Head Up Button

Used to raise the head of the bed base.

Foot Up Button

Used to raise the foot of the bed base.

Head Down Button

Used to lower the head of the bed base.

Lumber Raise/Down Buttons

Use to raise or lower the lumber of the bed

Under bed light Button

Press to turn on the underbed light, turn off automatically after 5 minutes. or press again to turn off the underbed light.

Head Massage Increase Button

Turn the head massage on , Increase massage intensity for the head.

Head Massage Decrease Button

Once head massage is turned on, press to decrease massage intensity. Once massage is at the lowest intensity, press again to turn massage off.

All Off Button

Use to turn off the head and foot massage.

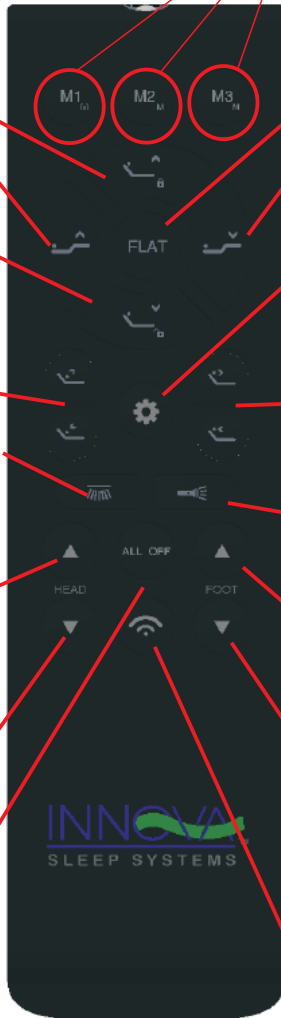

For toll-free customer service, call 1-877-386-1373

email us: service@innovasleep.com

Please tell us your name, phone, address, Model Name and/or Model ID (found on the law label tags, which are stapled to the head of the base), purchase date, and the question or concern when you call.

SYNCHRONIZING TWO BEDS

The bed base is designed to allow two twin XL bases to become an Eastern King base and two Split-Cal-King bases to become a Cal-King base. You can use the same Remote to control two side-by-side beds bases by following Step 6 on the installation guide to synchronize one Remote with the two Control Boxes of the two units.

After base A is paired by following the directions in Step 6, plug in base B and wait for the base to return to flat. You will hear a beep, and it will enter the pairing state for 10 seconds. (If not paired within 10 seconds, please press the SYNC button to enter the pairing mode on base B.)

Using the same remote, simultaneously press the FOOT UP and FOOT DOWN button for 3-5 seconds. You will hear a beep to signal pairing is complete.



Remote A

USING BOTH REMOTES ON THE SAME BED

Sync the Remote A with the 2 control boxes by following the above directions for Synchronizing Two Beds.

Then sync the Remote B by following the above directions for Synchronizing Two Beds.

Now both Wireless Remotes will be able to control both beds.

DESYNCHRONIZING TWO REMOTES

To remove syncing on one remote, press the SYNC button for 3-5 seconds. You will hear a beep to confirm that the base is ready to sync. To pair again, refer to Step 6 to sync base A with remote A and base B with Remote B, individually.